

# 1980 BMW 800

## LEFT REAR AXLE BRACKET INSTALLED

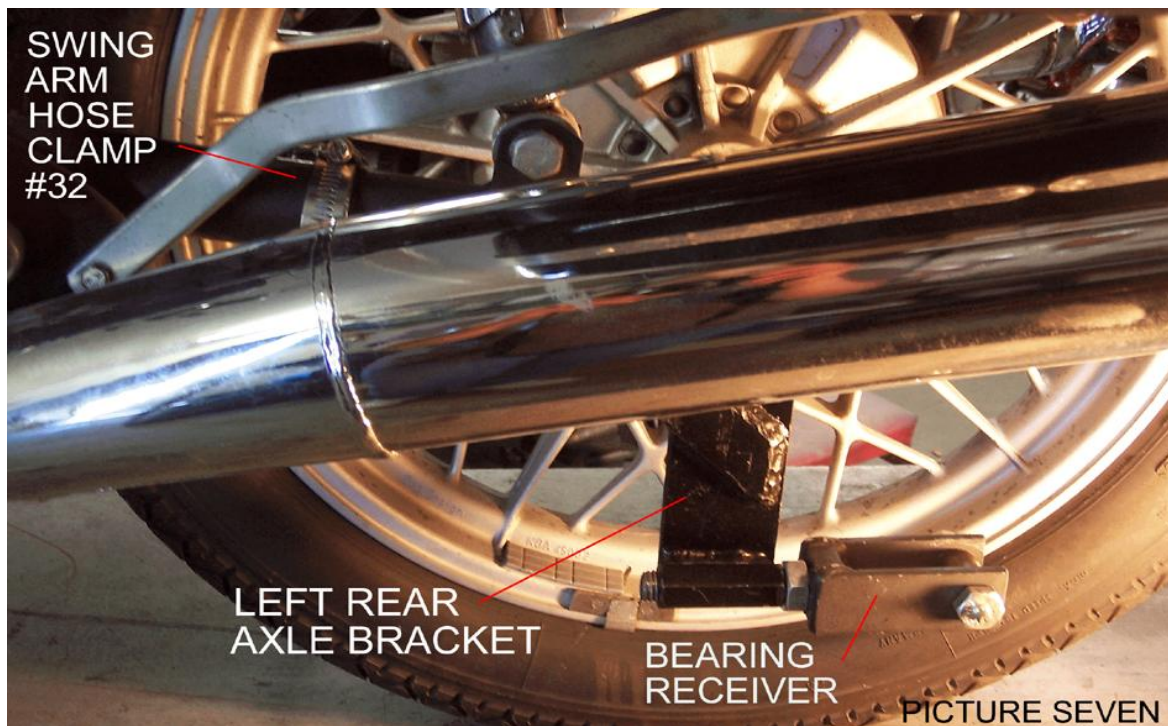

**1980 BMW 800  
RIGHT REAR AXLE BRACKET INSTALLED**

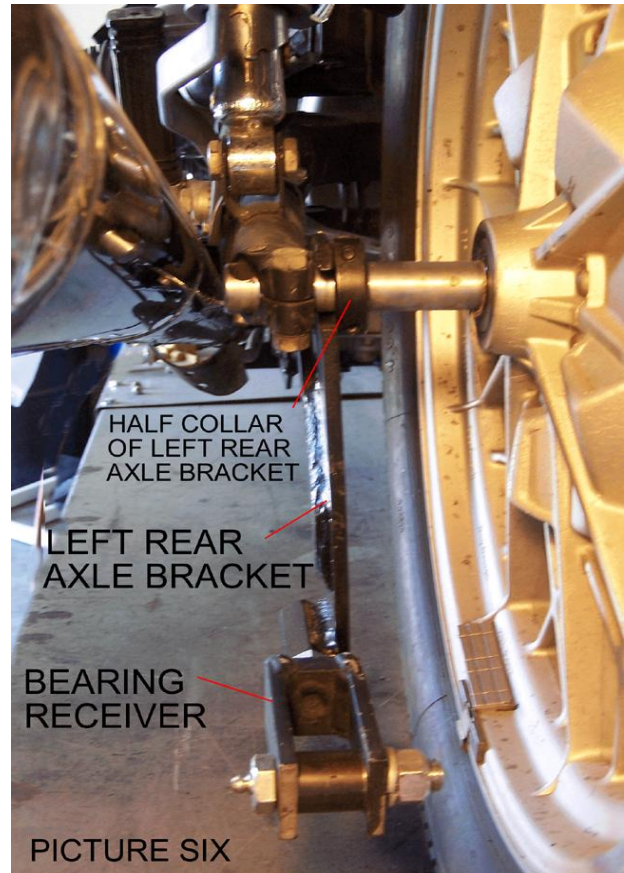
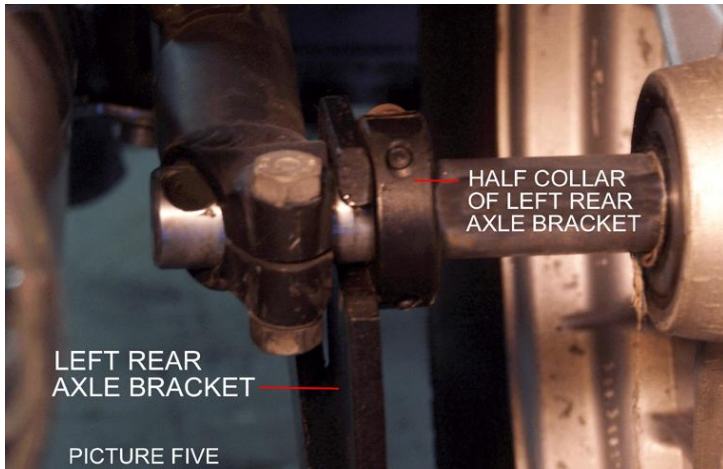
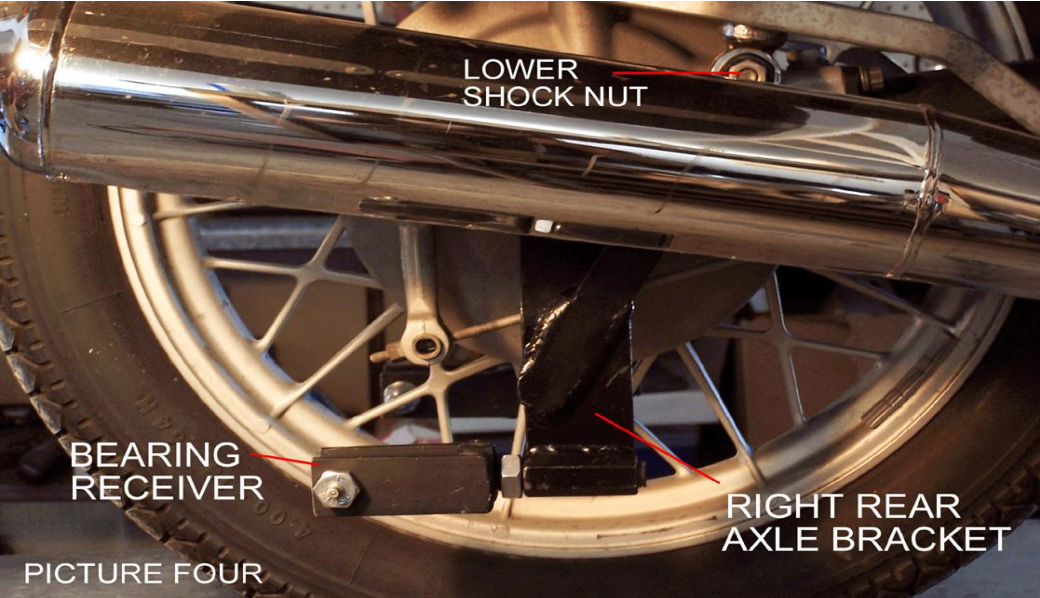
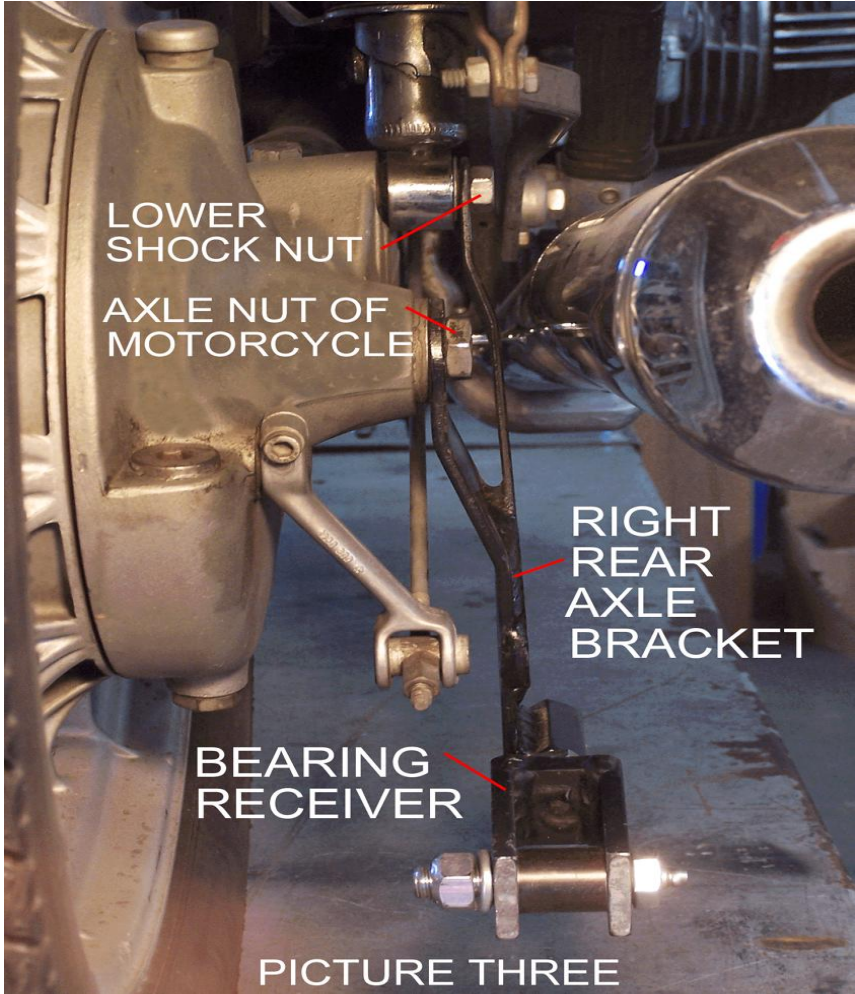

**1980 BMW 800  
BELLY BRACKET INSTALLED**

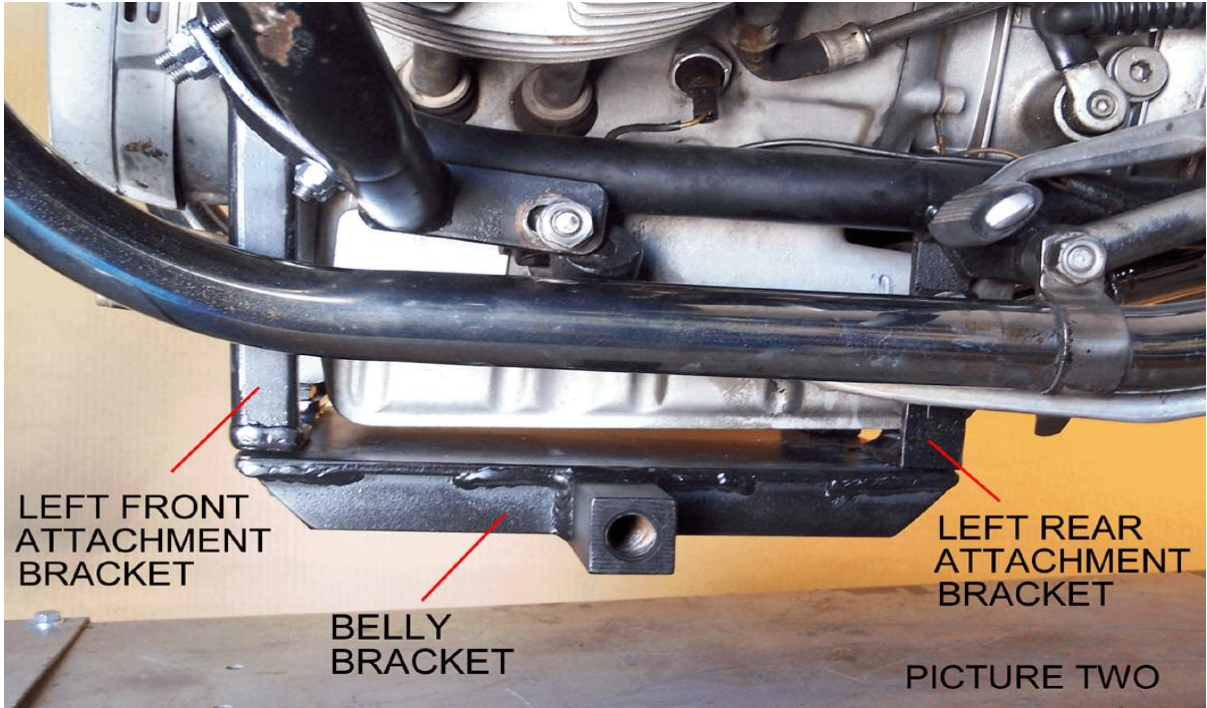
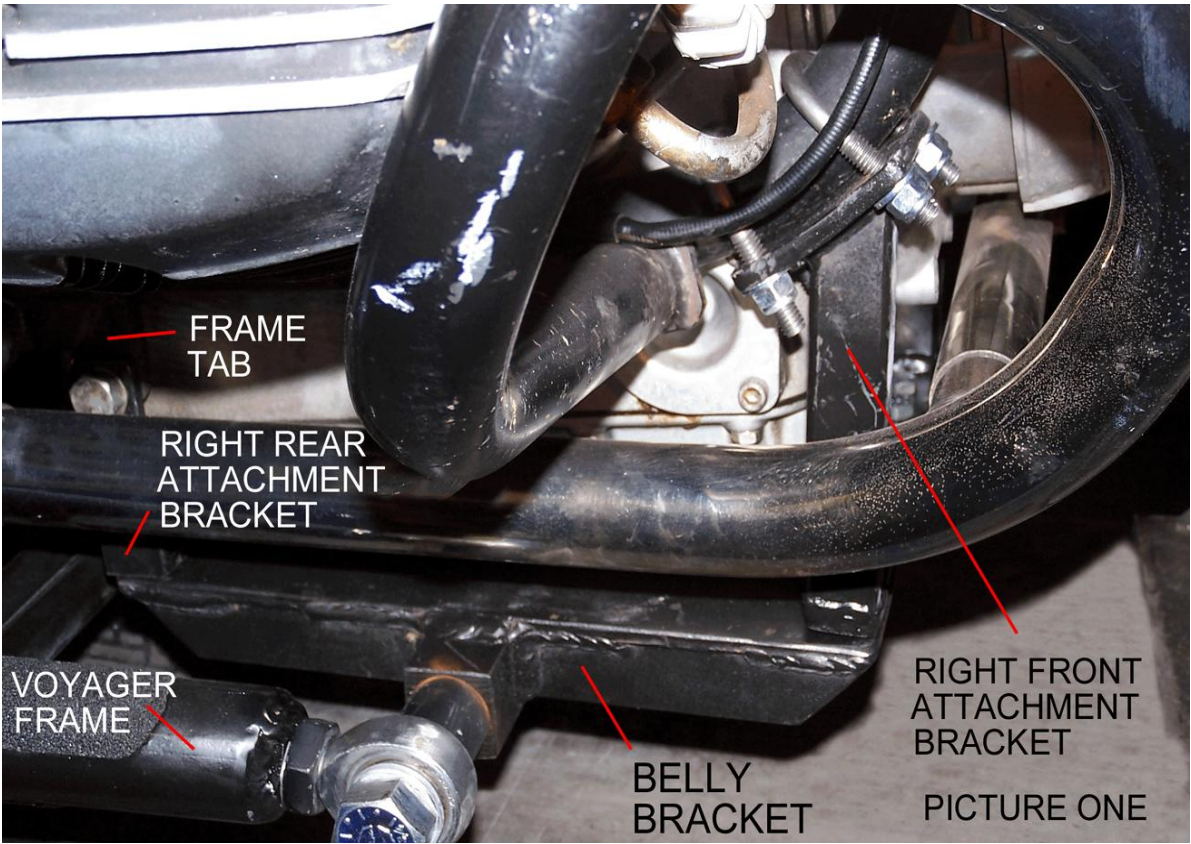

# 1980 BMW 800 DESCRIPTION OF PARTS

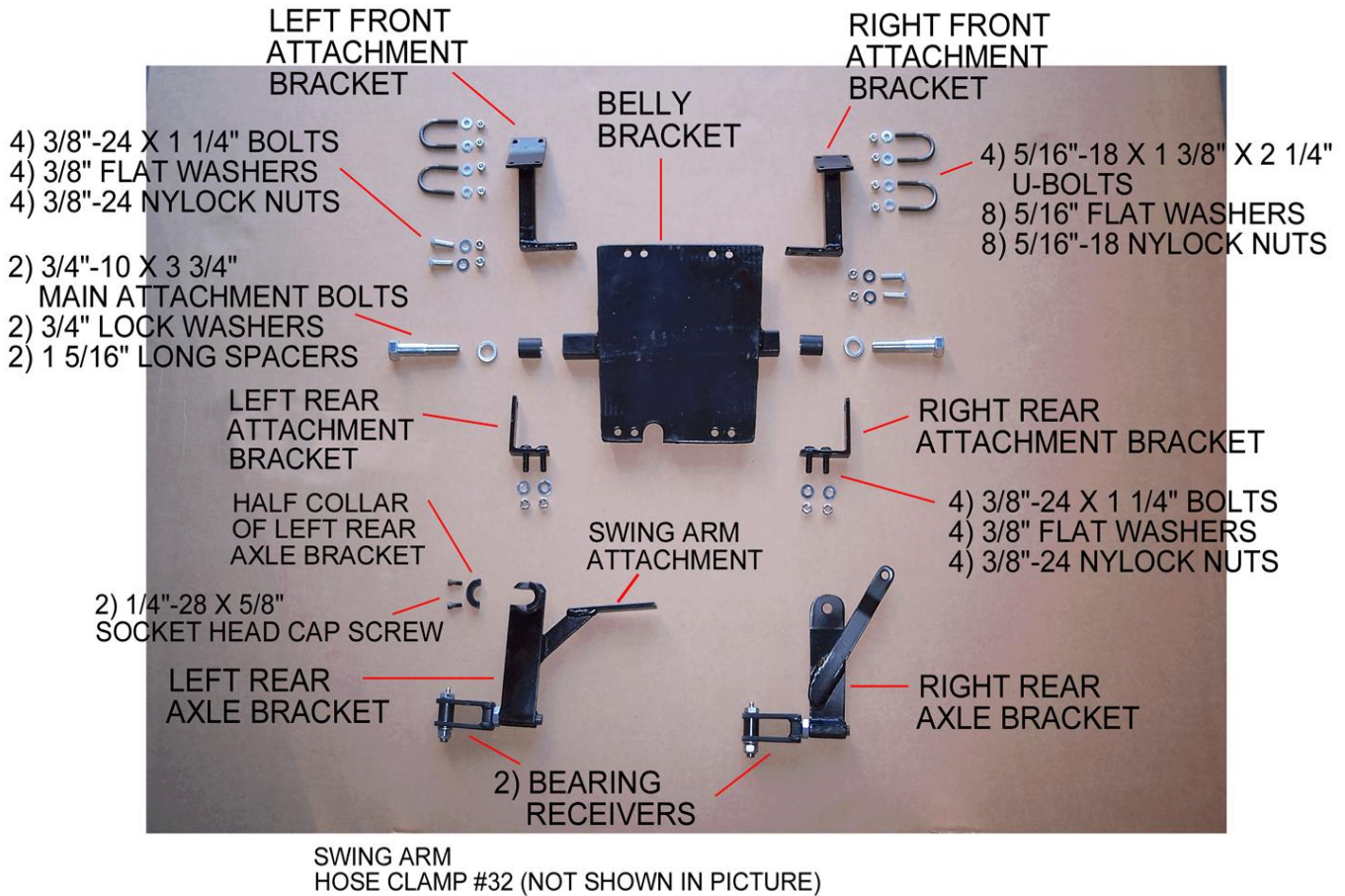

Four 3/8" washers used as shims– not shown in picture above.  
You may or may not have to use the shims. See note below.

After installing the mounting hardware and attaching the Voyager frame to the belly bracket you may need shims to make the motorcycle stand straight up and down. The shims may be used on either the left or the right side depending on which way the motorcycle is leaning. If the motorcycle is leaning to the left put the shims on the left side. If the motorcycle is leaning to the right put the shims on the right side.

**Place shims in-between belly bracket and front attachment bracket;  
 and in-between belly bracket and rear attachment bracket.**

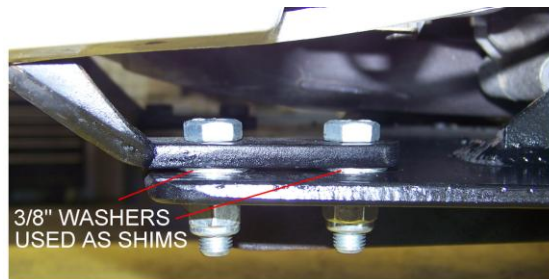

ILLUSTRATION OF SHIM PLACEMENT  
 BRACKET PICTURED MAY NOT MATCH YOUR BRACKET

# SECTION 1

## INSTALLATION OF

### 1980 BMW 800 MOUNTING HARDWARE

Place motorcycle on a clean flat surface. Make sure motorcycle is tied down on both sides to prevent it from tipping during installation of hardware. Installation is easier if motorcycle is in an upright position.

**Disconnect negative cable from battery before beginning installation.**

**NOTE:** The Voyager Convertible Kit was designed for a stock motorcycle from the manufacturer. Any after market products that are on a stock motorcycle may cause the installation process to not be done properly and may or may not need to be removed to be able to install the Voyager Convertible Kit completely. Be aware that your motorcycle and the same make & model as someone else's motorcycle may not have mufflers, body panels, frames, fenders and any other manufacturer parts that are attached to the motorcycle in the exact same place as yours. We at Motorcycle Tour Conversion, Inc. take that into consideration when we manufacture our parts to fit your motorcycle. Once in awhile you may need to modify your motorcycle slightly so that the Motorcycle Tour Conversion, Inc. hardware or suspension fits your motorcycle. Please call Motorcycle Tour Conversion, Inc. if you have any questions about installation with after market products or any modification of motorcycle and/or Motorcycle Tour Conversion, Inc. hardware.

#### A) BELLY BRACKET ATTACHMENT ARMS

1. Locate the right front attachment bracket. Install to frame of motorcycle with (2) 5/16"-18 x 1 3/8" x 2 1/4" u-bolts, (4) 5/16" flat washer, and (4) 5/16-18 nylock nuts. Refer to picture one.
2. Locate the left front attachment bracket. Install to frame of motorcycle with (2) 5/16"-18 x 1 3/8" x 2 1/4" u-bolts, (4) 5/16" flat washer, and (4) 5/16-18 nylock nuts. Refer to picture two.
3. Locate the right rear attachment bracket. Just in front of the motorcycle foot pegs there is a tab on the frame of the motorcycle with a bolt. Remove the bolt and attach right rear attachment bracket to tab with same bolt. Refer to picture one.
4. Locate the left rear attachment bracket. Just in front of the motorcycle foot pegs there is a tab on the frame of the motorcycle with a bolt. Remove the bolt and attach left rear attachment bracket to tab with same bolt. Refer to picture two.

# **SECTION 1**

## **INSTALLATION OF**

### **1980 BMW 800 MOUNTING HARDWARE**

#### **B) BELLY BRACKET**

1. Install belly bracket to attachment arms making sure the cut out in belly bracket is facing the rear of the motorcycle. Install front of belly bracket using (4) 3/8"-24 x 1 1/4" bolts, (4) 3/8" flat washers, and (4) 3/8-24 nylock nuts.
2. Install rear of belly bracket using (4) 3/8"-24 x 1 1/4" bolts, (4) 3/8" flat washers, and (4) 3/8-24 nylock nuts.

#### **C) LEFT REAR AXLE BRACKET**

1. Remove half collar of left rear axle bracket, install left rear axle bracket over axle bolt and replace half collar. (Do not tighten at this time) Attach swing arm attachment of left rear axle bracket to swing arm of motorcycle with the hose clamp provided with the kit. Now tighten half collar. Refer to picture 3.

#### **D) RIGHT REAR AXLE BRACKET**

1. Remove axle nut of motorcycle and lower shock nut.
2. Install right rear axle bracket over lower shock bolt and then over axle bolt and replace both nuts. Refer to picture 4.



MOTORCYCLE TOUR CONVERSION, INC.  
1530 TITANIUM DR  
OTTAWA, IL. 61350

TOLL FREE: 877-434-7901  
FAX: 815-434-8980

## **1980 BMW 800**

INSTALLATION MANUAL  
US PATENT # 6,739,420

**WARRANTY WILL BE VOID IF INSTALLATION  
IS NOT DONE PROPERLY**

**READ THIS MANUAL FULLY BEFORE  
BEGINNING INSTALLATION OR DRIVING YOUR  
MOTORCYCLE WITH THE VOYAGER KIT ATTACHED**