

YAMAHA V-STAR 1300 REAR AXLE BRACKETS INSTALLED

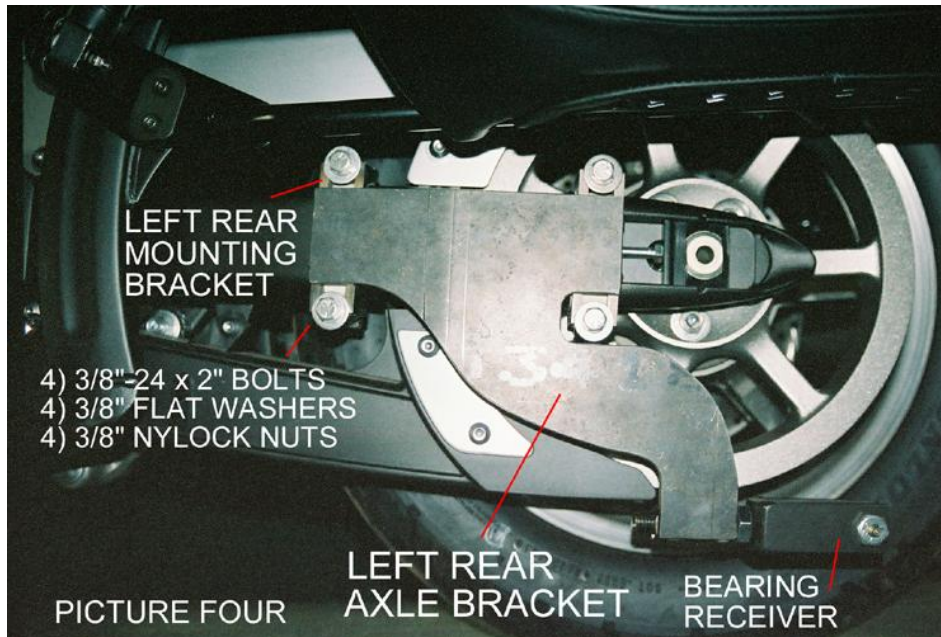

YAMAHA V-STAR 1300 BELLY BRACKET INSTALLED

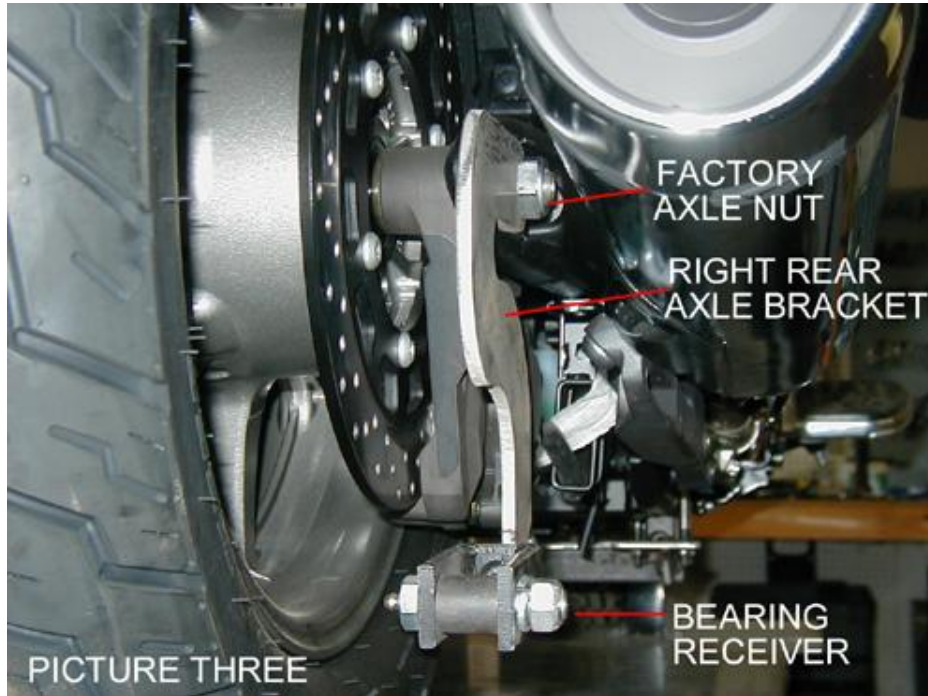
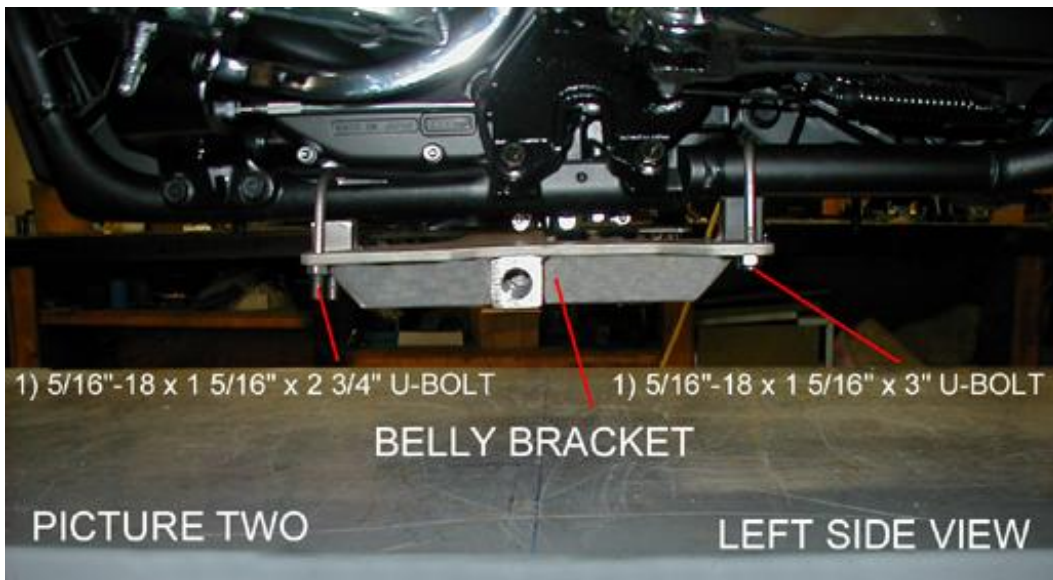
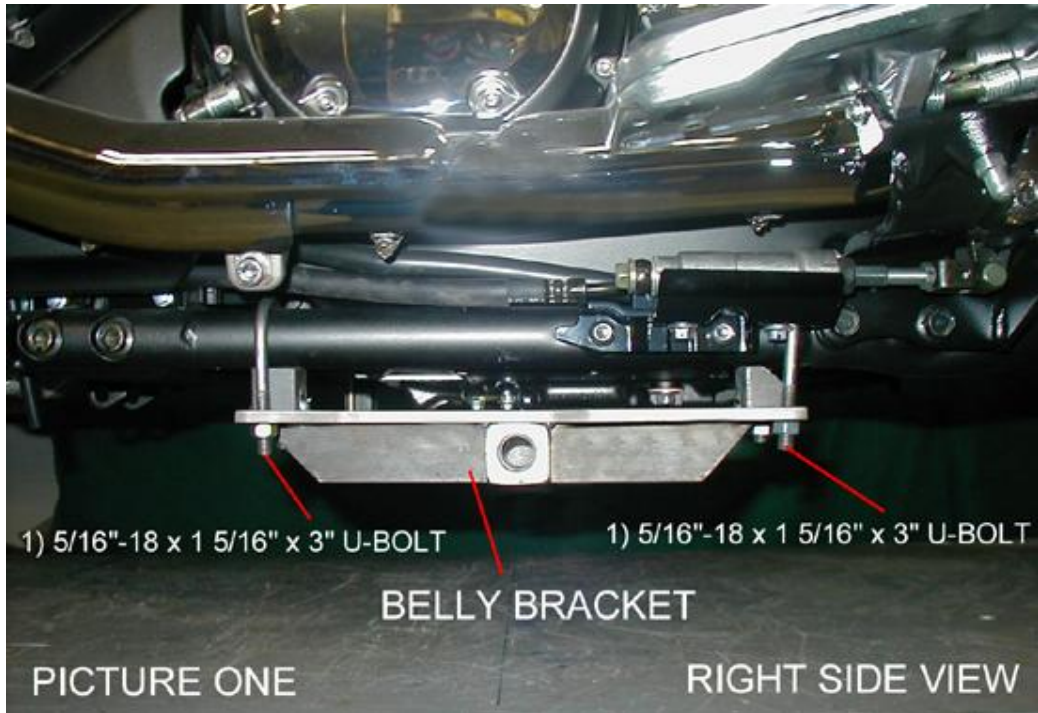

YAMAHA V-STAR 1300

DESCRIPTION OF PARTS

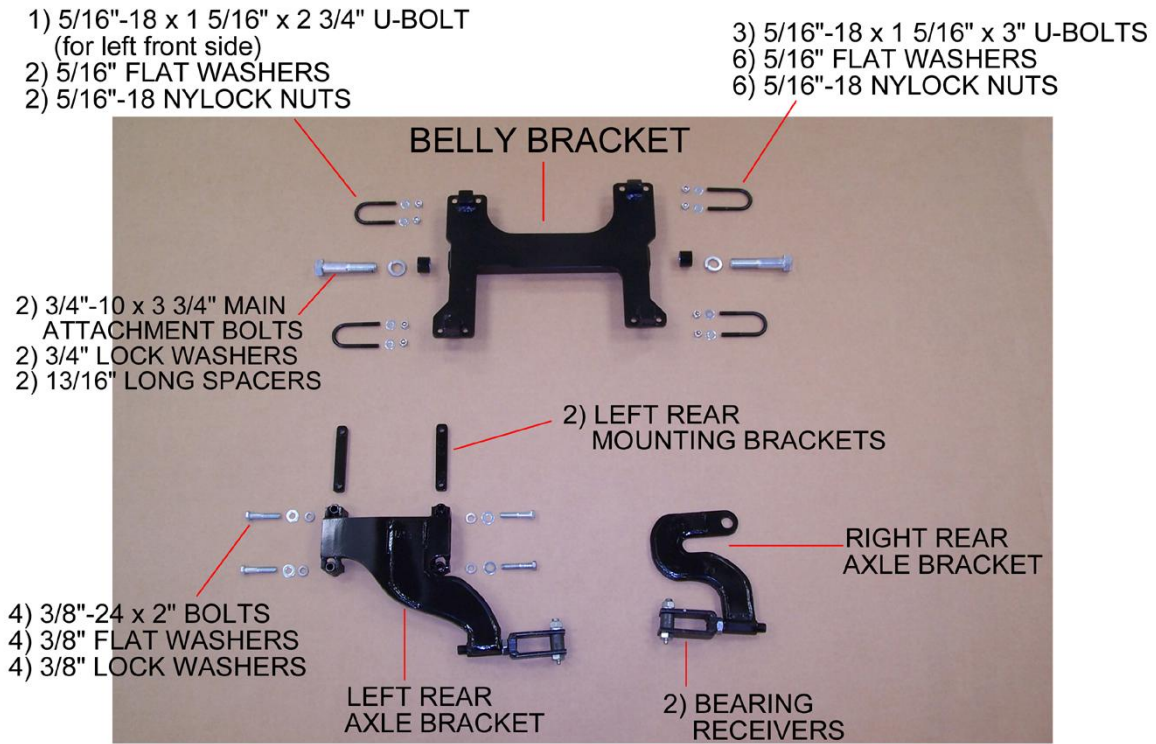

Two 2" shims– not shown in picture above.
 You may or may not have to use the shims. See note below.

After installing the mounting hardware and attaching the Voyager frame to the belly bracket you may need shims to make the motorcycle stand straight up and down. The shims may be used on either the left or the right side depending on which way the motorcycle is leaning. If the motorcycle is leaning to the left put the shims on the left side. If the motorcycle is leaning to the right put the shims on the right side. The shims will go on the front and back of one side of the belly bracket.

Place shims in-between belly bracket tabs and motorcycle frame.

SHIM SHIM

ILLUSTRATION OF SHIM PLACEMENT
 BRACKET PICTURED MAY NOT MATCH YOUR BRACKET

SECTION 1

INSTALLATION OF YAMAHA V-STAR 1300 MOUNTING HARDWARE

Place motorcycle on clean flat surface. Make sure your motorcycle is tied down on both sides. This prevents bike from tipping over. Installation is easier if motorcycle is in an upright position.

Disconnect negative cable from battery before beginning installation.

NOTE: The Voyager Convertible Kit was designed for a stock motorcycle from the manufacturer. Any after market products that are on a stock motorcycle may cause the installation process to not be done properly and may or may not need to be removed to be able to install the Voyager Convertible Kit completely. Be aware that your motorcycle and the same make & model as someone else's motorcycle may not have mufflers, body panels, frames, fenders and any other manufacturer parts that are attached to the motorcycle in the exact same place as yours. We at Motorcycle Tour Conversion, Inc. take that into consideration when we manufacture our parts to fit your motorcycle. Once in awhile you may need to modify your motorcycle slightly so that the Motorcycle Tour Conversion, Inc. hardware or suspension fits your motorcycle. Please call Motorcycle Tour Conversion, Inc. if you have any questions about installation with after market products or any modification of motorcycle and/or Motorcycle Tour Conversion, Inc. hardware.

A) BELLY BRACKET

- 1) Install one u-bolt 5/16"-18 x 1 5/16" x 3" over frame of motorcycle on right side or brake side, behind floorboard attachment bracket.
- 2) Install the next u-bolt 5/16"-18 x 1 5/16" x 3" over frame of motorcycle about 10 3/8" behind first u-bolt.
- 3) Install one u-bolt 5/16"-18 x 1 5/16" x 2 3/4" over left side of motorcycle frame behind floorboard attachment bracket. **(Note: this size u-bolt used on front left side)**
- 4) Install the next u-bolt 5/16"-18 x 1 5/16" x 3" over frame of motorcycle about 10 1/8" behind first u-bolt.
- 5) Install belly bracket to u-bolts with 5/16" flat washers and 5/16"-18 nylock nuts. (Shown in pictures one & two)

SECTION 1 INSTALLATION OF YAMAHA V-STAR 1300 MOUNTING HARDWARE

B) REAR AXLE BRACKETS

RIGHT REAR AXLE BRACKET

- 1) Remove factory axle nut.
- 2) Install right rear axle bracket over axle bolt and replace factory axle nut and tighten. (Shown in picture three)

LEFT REAR AXLE BRACKET

- 1) Place one left rear mounting bracket on inside of swing arm.
- 2) Place left rear axle bracket on outside of swing arm and attach to rear mounting bracket with 2) 3/8"-24 x 2" bolts, 2) 3/8" flat washers, 2) 3/8" lock washers.
- 3) Place the other left rear mounting bracket on inside of swing arm and attach to left rear axle bracket with 2) 3/8"-24 x 2" bolts, 2) 3/8" flat washers, 2) 3/8" lock washers. (Shown in picture four)



MOTORCYCLE TOUR CONVERSION, INC.
1530 TITANIUM DR.
OTTAWA, IL. 61350

TOLL FREE: 877-434-7901
FAX: 815-434-8980

YAMAHA V-STAR 1300

INSTALLATION MANUAL
US PATENT # 6,739,420

**WARRANTY WILL BE VOID IF INSTALLATION
IS NOT DONE PROPERLY**

**READ THIS MANUAL FULLY BEFORE
BEGINNING INSTALLATION OR DRIVING YOUR
MOTORCYCLE WITH THE VOYAGER KIT ATTACHED**