

**KAWASAKI VOYAGER 1200  
LEFT REAR AXLE BRACKET INSTALLED**

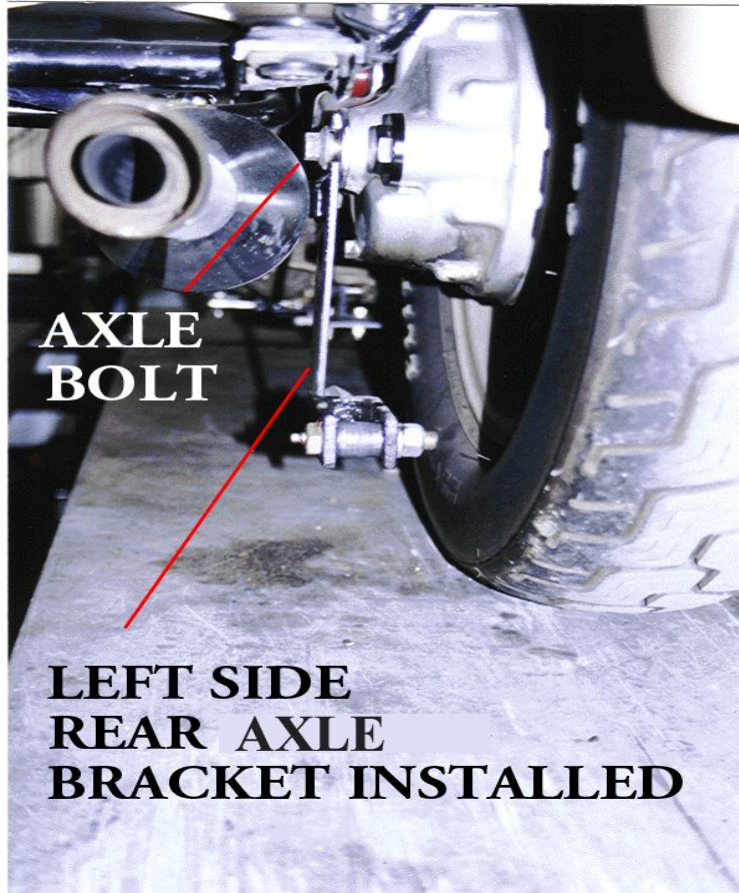

**KAWASAKI VOYAGER 1200  
RIGHT REAR AXLE BRACKET INSTALLED**

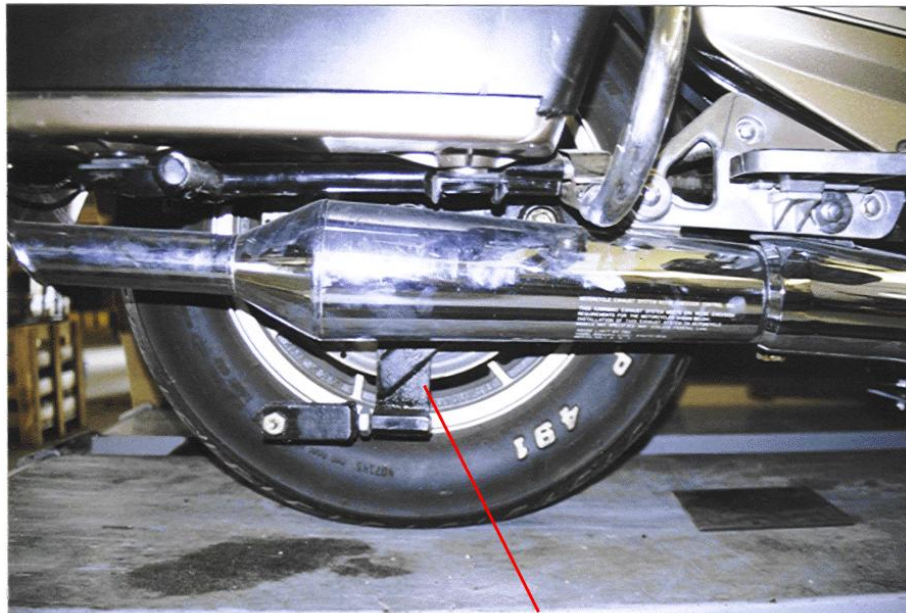
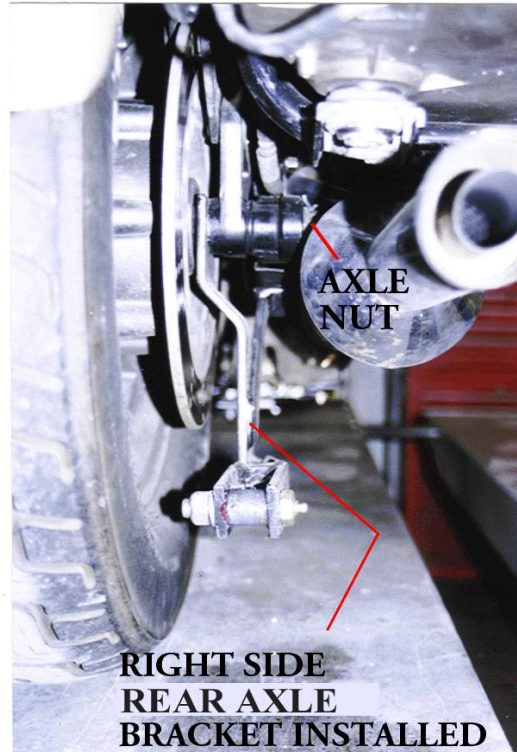

**RIGHT SIDE REAR AXLE BRACKET INSTALLED**

**KAWASAKI VOYAGER 1200  
LEFT SIDE VIEW OF BELLY BRACKET INSTALLED**

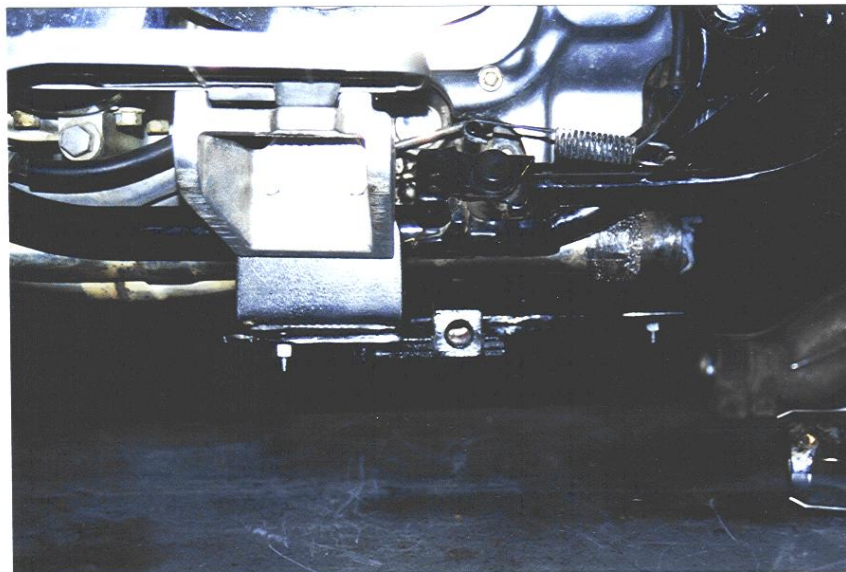
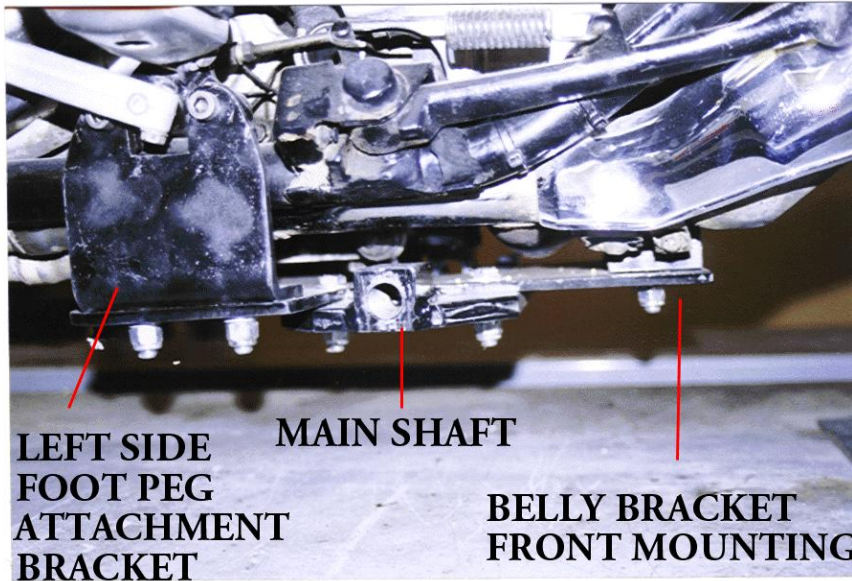

**INSTALLED WITH DIFFERENT  
FOOT PEG BRACKET ON BIKE**

**KAWASAKI VOYAGER 1200  
RIGHT SIDE VIEW OF BELLY BRACKET INSTALLED**

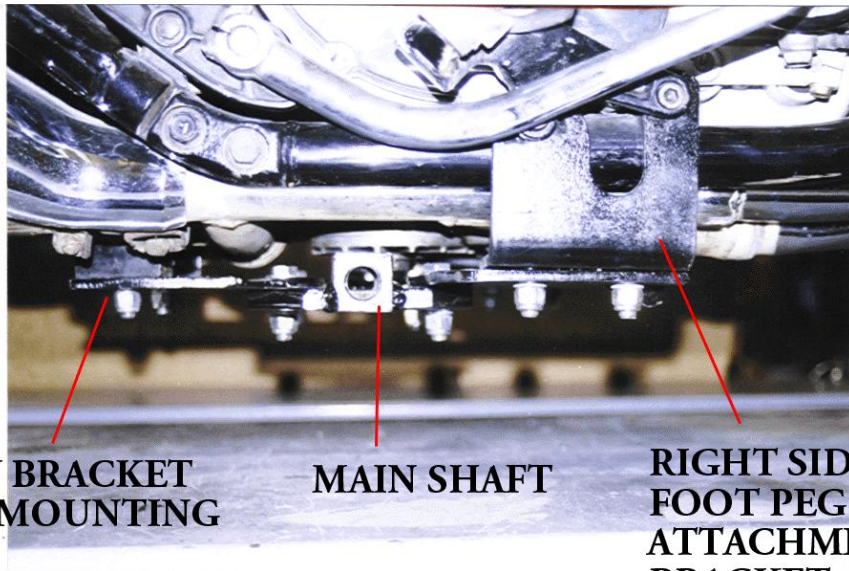

**BELLY BRACKET  
REAR MOUNTING**

**MAIN SHAFT**

**RIGHT SIDE  
FOOT PEG  
ATTACHMENT  
BRACKET**

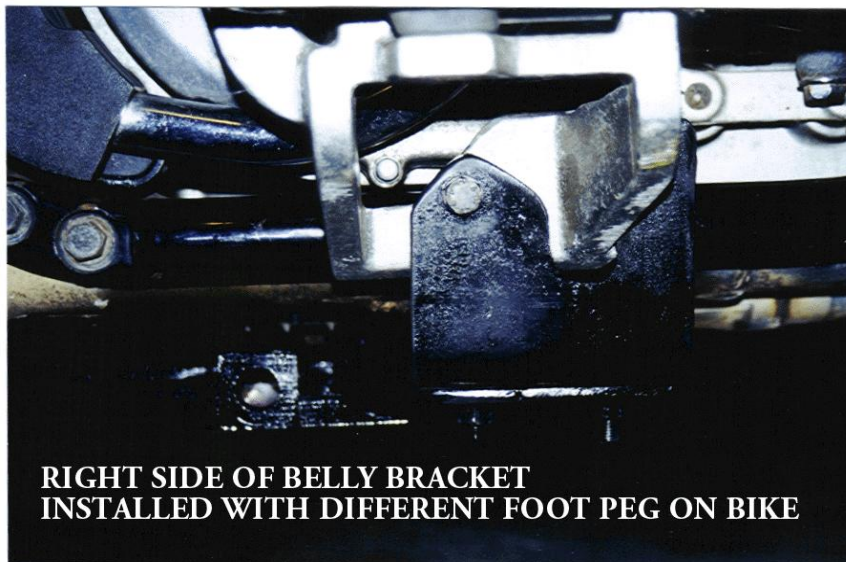

**RIGHT SIDE OF BELLY BRACKET  
INSTALLED WITH DIFFERENT FOOT PEG ON BIKE**

# KAWASAKI VOYAGER 1200

## DESCRIPTION OF PARTS (cont.)

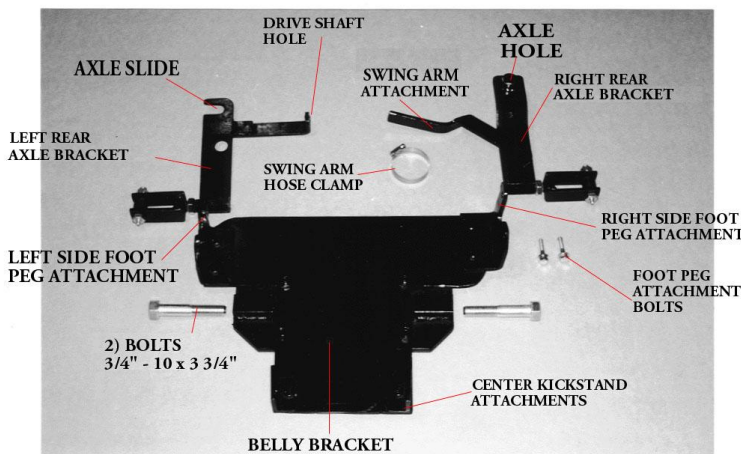
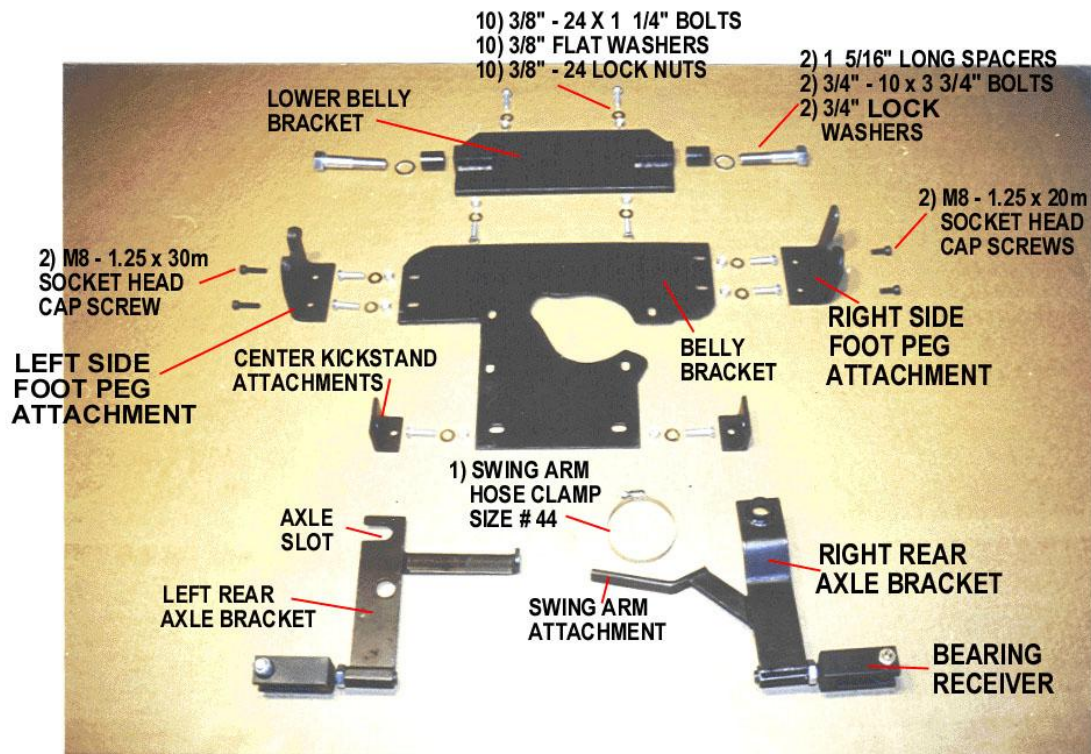

Two 3/8" washers used as shims—  
 not shown in picture above.  
 You may or may not have to use the shims.  
 See note on following page.

After installing the mounting hardware and attaching the Voyager frame to the belly bracket you may need shims to make the motorcycle stand straight up and down. The shims may be used on either the left or the right side depending on which way the motorcycle is leaning. If the motorcycle is leaning to the left put the shims on the left side. If the motorcycle is leaning to the right put the shims on the right side.

**Place shims over 3/8" holes on top of lower belly bracket. Shims may be used on either the left or right side depending on which way bike is leaning. Install lower belly bracket to main belly bracket.**

# SECTION 1

## INSTALLATION OF

### KAWASAKI VOYAGER 1200

### MOUNTING HARDWARE

Place motorcycle on a clean flat surface. Make sure to tie down motorcycle so it does not tip over during installation of hardware. Installation is easier if motorcycle is in an upright position.

**Disconnect negative cable from battery before beginning installation.**

**NOTE:** The Voyager Convertible Kit was designed for a stock motorcycle from the manufacturer. Any after market products that are on a stock motorcycle may cause the installation process to not be done properly and may or may not need to be removed to be able to install the Voyager Convertible Kit completely. Be aware that your motorcycle and the same make & model as someone else's motorcycle may not have mufflers, body panels, frames, fenders and any other manufacturer parts that are attached to the motorcycle in the exact same place as yours. We at Motorcycle Tour Conversion, Inc. take that into consideration when we manufacture our parts to fit your motorcycle. Once in awhile you may need to modify your motorcycle slightly so that the Motorcycle Tour Conversion, Inc. hardware or suspension fits your motorcycle. Please call Motorcycle Tour Conversion, Inc. if you have any questions about installation with after market products or any modification of motorcycle and/or Motorcycle Tour Conversion, Inc. hardware.

**Note:** (Will have to remove lower belly bracket to change oil and oil filter)

#### A) BELLY BRACKET

- 1) Split and remove exhaust from rear of engine back.
- 2) Remove center kick stand.
- 3) Remove right side foot peg.
- 4) Remove shifter.
- 5) Remove left side foot peg.
- 6) Install center kickstand attachments to center stand brackets on motorcycle using existing bolts of motorcycle. (Make sure you install the (2) 3/8"-24 x 1 1/4" bolts & the (2) Flat washers into the bottom holes of the center kickstand attachments before you attach them to the center stand of motorcycle.)

# SECTION 1

## INSTALLATION OF KAWASAKI VOYAGER 1200 MOUNTING HARDWARE

- 7) Attach rear of belly bracket to the center kickstand attachments using the (2) 3/8"-24 lock nuts provided with the kit. (Do not tighten at this time.)
- 8) Attach the (2) Foot Peg Attachments to the front sides of belly bracket using the (4) 3/8"-24 x 1 1/4" bolts, flat washers, and lock nuts. (Do not tighten at this time.)
- 9) Place the last (4) 3/8"-24 x 1 1/4" bolts with flat washers into the top of the belly bracket's remaining 4 holes. (Holes are more to center of the belly bracket. These are for mounting the lower belly bracket.)
- 10) Tilt belly bracket up and attach left side Foot Peg Attachment between left side foot peg of motorcycle and frame with bolts provided with Voyager kit. (M8-1.25 x 30m)
- 11) Attach right side Foot Peg Attachment to outside of foot peg of motorcycle with bolts provided. (M8-1.25 x 20)
- 12) Replace shifter at this time.
- 13) Tighten all belly bracket bolts at this time.
- 14) Attach lower belly bracket using the (4) remaining 3/8"-24 lock nuts.

**Note:** (Will have to remove lower belly bracket to change oil and oil filter)

### **B) REAR AXLE BRACKETS**

- 1) Remove axle retaining nut.
- 2) Drive out axle until you can remove the spacer that fits between the brake caliper and the wheel on right side of motorcycle.
- 3) Replace that spacer with the right side axle bracket
- 4) Remove the outer drive shaft housing nut.

# **SECTION 1**

## **INSTALLATION OF**

### **KAWASAKI VOYAGER 1200**

#### **MOUNTING HARDWARE**

- 5) Slide the left rear axle bracket onto the axle.
- 6) Tighten the drive shaft housing nut.
- 7) Reinsert the axle, But Do Not Tighten.
- 8) Make sure swing arm attachment of axle bracket and swing arm are touching.
- 9) Clamp the right rear axle bracket swing arm attachment to the swing arm on motorcycle using the hose clamp provided with the kit.
- 10) Tighten the axle nut.





MOTORCYCLE TOUR CONVERSION, INC.  
1530 TITANIUM DR  
OTTAWA, IL. 61350

TOLL FREE: 877-434-7901  
FAX: 815-434-8980

## **KAWASAKI VOYAGER 1200**

INSTALLATION MANUAL  
US PATENT # 6,739,420

**WARRANTY WILL BE VOID IF INSTALLATION  
IS NOT DONE PROPERLY**

**READ THIS MANUAL FULLY BEFORE  
BEGINNING INSTALLATION OR DRIVING YOUR  
MOTORCYCLE WITH THE VOYAGER KIT ATTACHED**