

# KAWASAKI VULCAN 1500 REAR AXLE BRACKETS INSTALLED

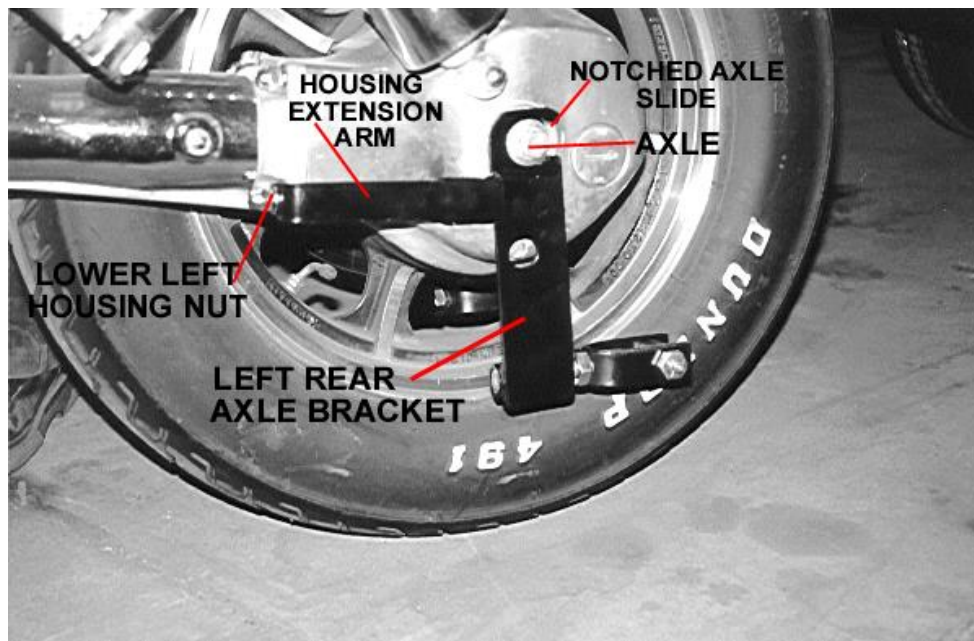

# KAWASAKI VULCAN 1500 BELLY BRACKET ATTACHMENT POINTS

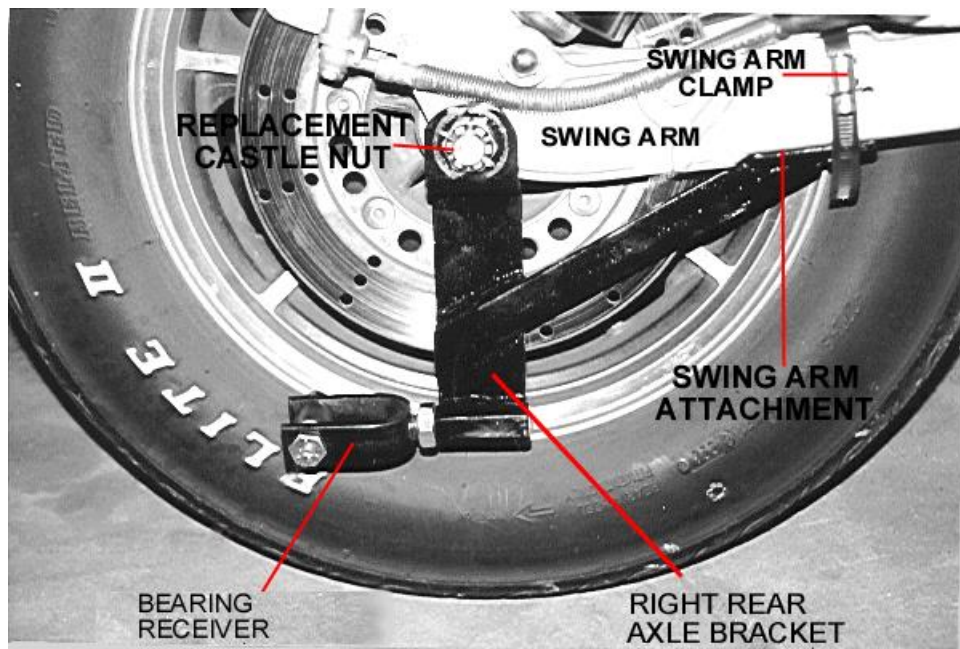

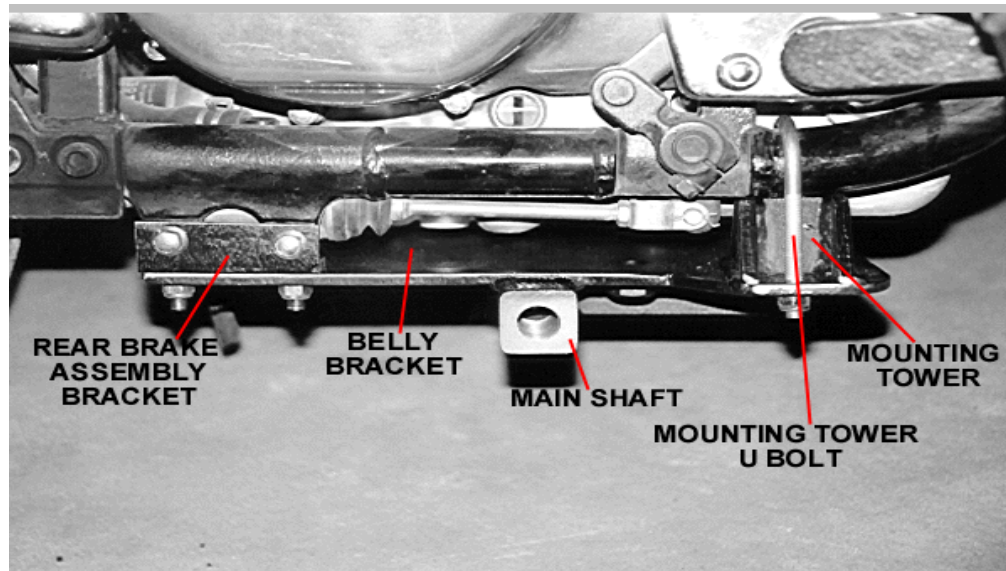
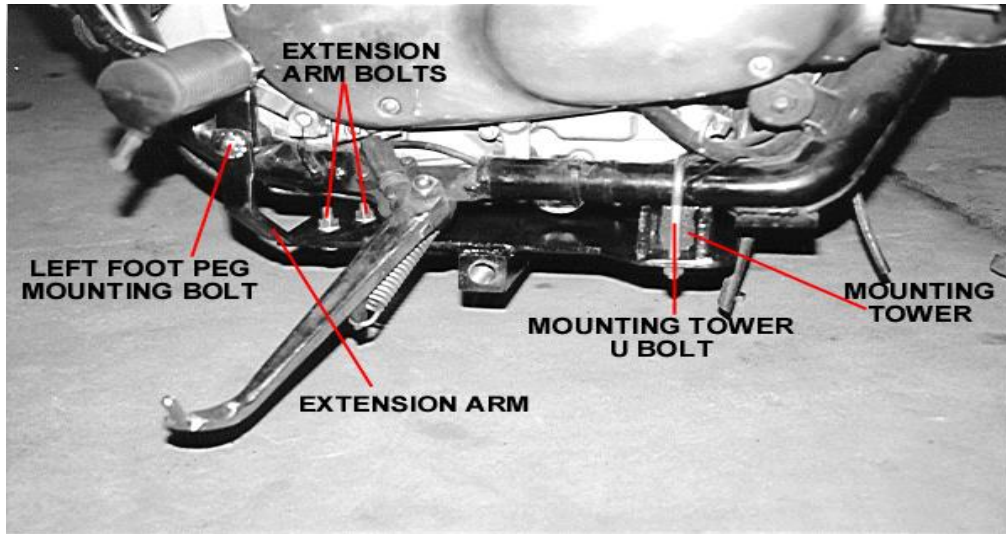

# KAWASAKI VULCAN 1500 DESCRIPTION OF PARTS

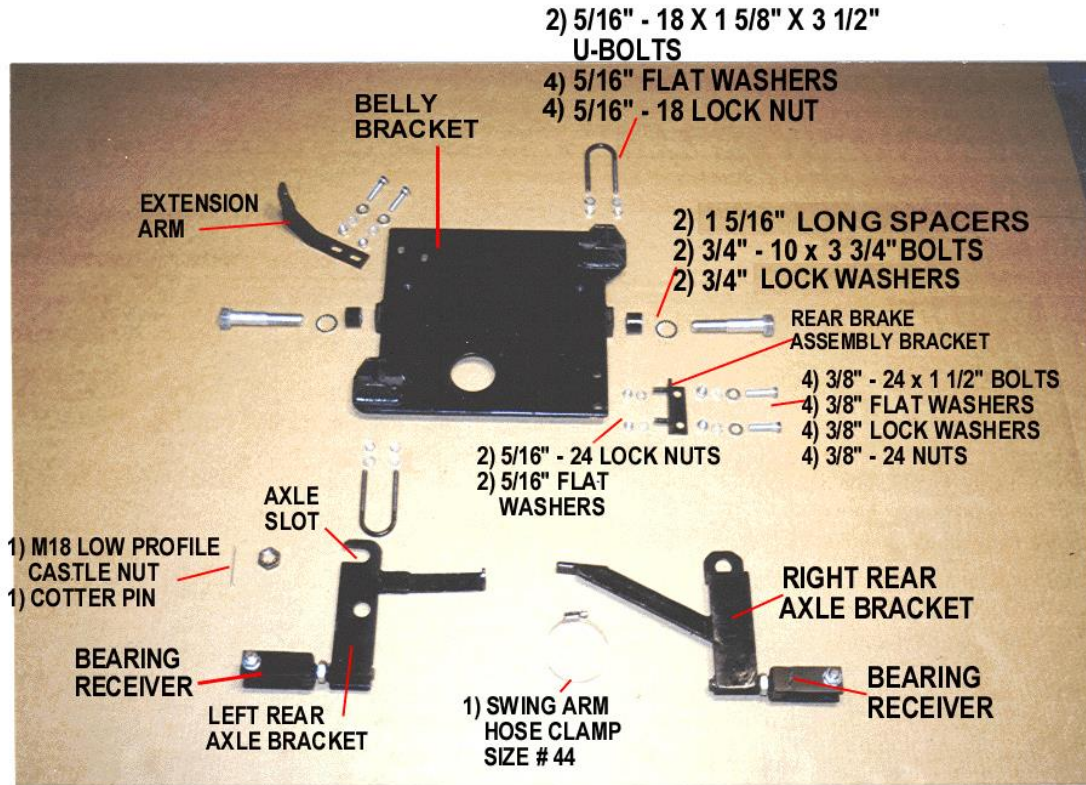

One 1 1/2" shim and Two 3/8" washers used as shims – not shown in picture above.  
 You may or may not have to use the shims. See note below.

After installing the mounting hardware and attaching the Voyager frame to the belly bracket you may need shims to make the motorcycle stand straight up and down.  
 The shims will go on the front and back of the right side of the belly bracket.

## Right side only

Place 1 1/2" shim in-between belly bracket front tab and motorcycle frame.

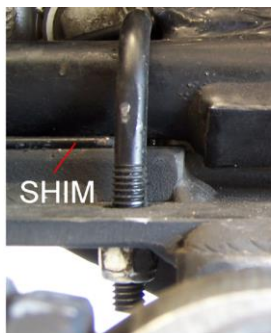

ILLUSTRATION OF SHIM PLACEMENT  
 BRACKET PICTURED MAY NOT MATCH YOUR BRACKET

Place 3/8" washers in-between belly bracket and rear brake assembly bracket.



ILLUSTRATION OF SHIM PLACEMENT  
 BRACKET PICTURED MAY NOT MATCH YOUR BRACKET

# SECTION 1

## INSTALLATION OF KAWASAKI VULCAN 1500 MOUNTING HARDWARE

Place motorcycle on a clean flat surface. Be sure to tie down motorcycle so it does not tip over during installation of Voyager hardware. Installation is easier if motorcycle is in an upright position.

**Disconnect negative cable from battery before beginning installation.**

**NOTE:** The Voyager Convertible Kit was designed for a stock motorcycle from the manufacturer. Any after market products that are on a stock motorcycle may cause the installation process to not be done properly and may or may not need to be removed to be able to install the Voyager Convertible Kit completely. Be aware that your motorcycle and the same make & model as someone else's motorcycle may not have mufflers, body panels, frames, fenders and any other manufacturer parts that are attached to the motorcycle in the exact same place as yours. We at Motorcycle Tour Conversion, Inc. take that into consideration when we manufacture our parts to fit your motorcycle. Once in awhile you may need to modify your motorcycle slightly so that the Motorcycle Tour Conversion, Inc. hardware or suspension fits your motorcycle. Please call Motorcycle Tour Conversion, Inc. if you have any questions about installation with after market products or any modification of motorcycle and/or Motorcycle Tour Conversion, Inc. hardware.

### A) BELLY BRACKET

- 1) Place motorcycle on a clean flat surface. (It helps to tighten motorcycle down in an upright level position.)
- 2) Attach rear brake assembly bracket to rear brake assembly of motorcycle frame mounting bolts on right side. Attach belly bracket to lower bolts on rear brake assembly bracket using the (2) two 5/16"-24 lock nuts and the (2) two 5/16" flat washers.
- 3) Next install extension arm to the left foot peg mounting bolt. (lock washer provided) You may have to modify foot peg cover so that it will fit. Attach extension arm to left front of belly bracket using the (2) two 3/8" - 24 x 1 1/2" bolts, (2) two 3/8" flat washers, (2) two 3/8" lock washers and (2) two 3/8" -24 nuts. (Extension arm lays on top of belly bracket)
- 4) Place two u-bolts over frame where belly bracket mounting towers are attached. Put u-bolts through belly bracket holes and attach and tighten 5/16" flat washers and 5/16" - 18 locking nuts to U-bolts.

# **SECTION 1**

## **INSTALLATION OF KAWASAKI VULCAN 1500 MOUNTING HARDWARE**

### **B) REAR AXLE BRACKETS**

1) Remove pin and castle nut of rear axle. Tap rear axle out about 1/4". Remove bottom left housing nut. Place attachment arm onto bottom left housing bolt, slide notched left rear axle bracket over axle. Replace drive shaft and tighten housing nut. (tap axle back into place)

2) Place right rear axle bracket over axle. Replace castle nut of motorcycle with castle nut provided with kit. Swing arm attachment should be touching swing arm on motorcycle clamp both together and tighten with swing arm clamp provided.

3) After the axle bolt and new castle nut are installed, drill a hole in the bolt to accommodate the cotter pin.

### **C) Alignment**

1) With Voyager attached to main shaft of belly bracket (no suspension on Voyager at this time). If trailer ball does not line up with rear of motorcycle loosen up nuts of u-bolts, extension arm, and mounting attachment of rear brake assembly bracket. Physically move the back of the Voyager over so that it lines up with the motorcycle. At this time tighten all nuts that you previously loosened on belly bracket.



MOTORCYCLE TOUR CONVERSION, INC.  
1530 TITANIUM DRIVE  
OTTAWA, IL 61350

TOLL FREE: 877-434-7901  
FAX: 815-434-8980

## **KAWASAKI VULCAN 1500**

INSTALLATION MANUAL  
US PATENT # 6,739,420

**WARRANTY WILL BE VOID IF INSTALLATION  
IS NOT DONE PROPERLY**

**READ THIS MANUAL FULLY BEFORE  
BEGINNING INSTALLATION OR DRIVING YOUR  
MOTORCYCLE WITH THE VOYAGER KIT ATTACHED**