

H-D SPORTSTER 1000 (1972-1978) REAR AXLE BRACKETS INSTALLED

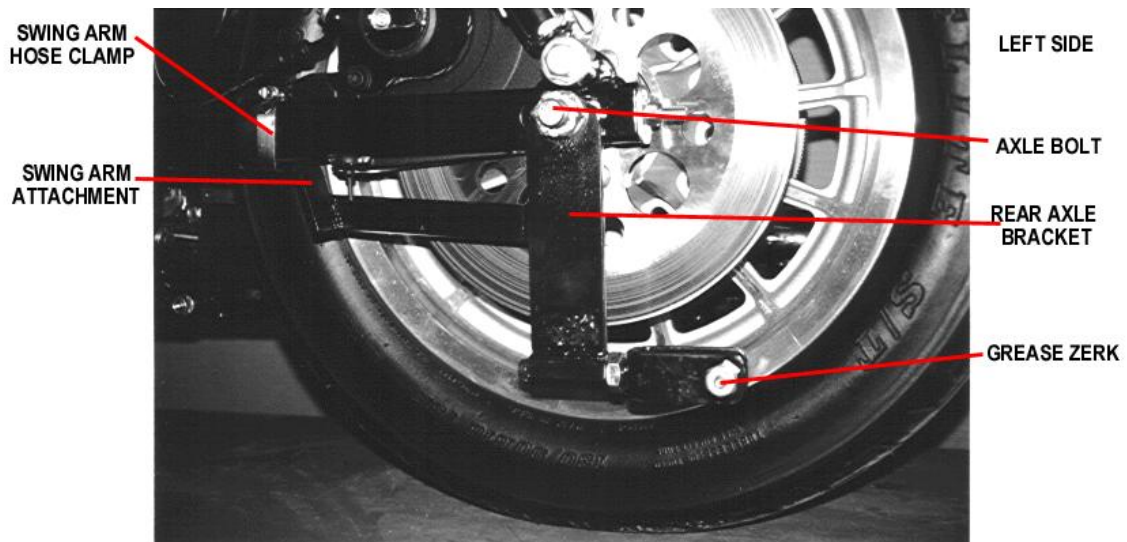

**H-D SPORTSTER 1000 (1972-1978)
BELLY BRACKET INSTALLED**

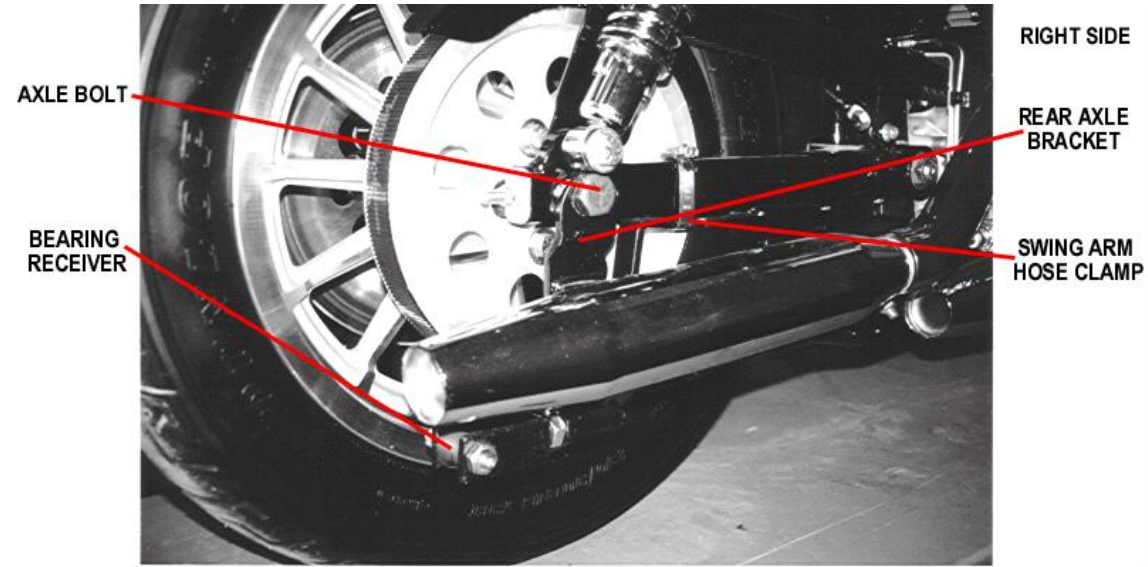
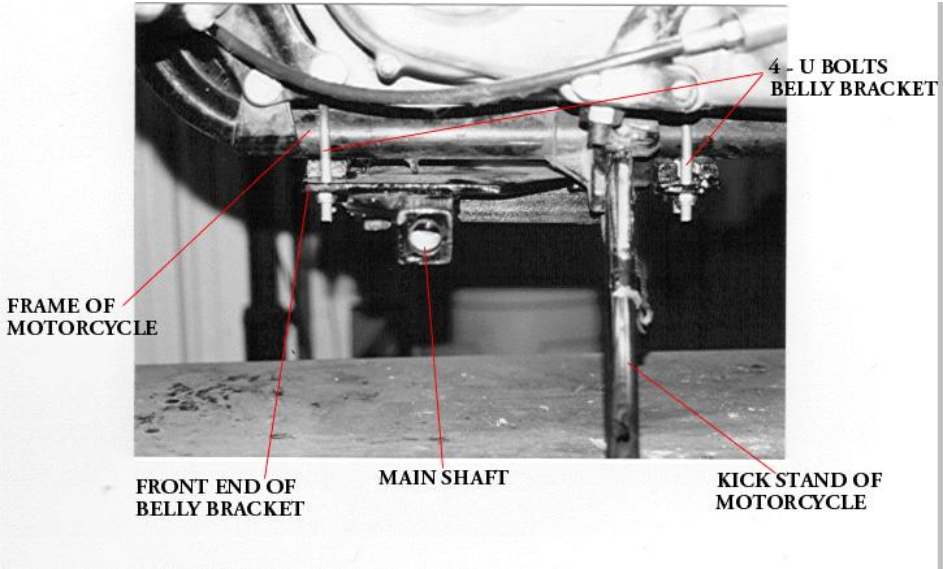

H-D SPORTSTER 1000 (1972-1978) DESCRIPTION OF PARTS

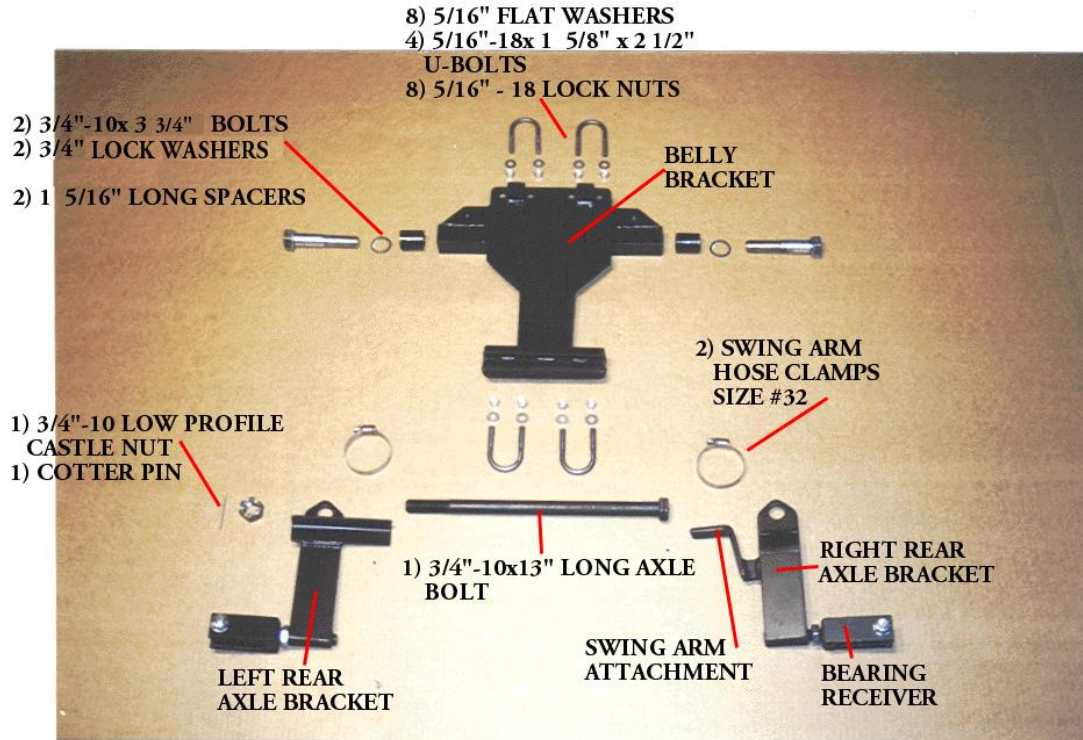

One 1" shim and one 2" shim – not shown in picture above.
You may or may not have to use the shims. See note below.

After installing the mounting hardware and attaching the Voyager frame to the belly bracket you may need shims to make the motorcycle stand straight up and down. The shims may be used on either the left or the right side depending on which way the motorcycle is leaning. If the motorcycle is leaning to the left put the shims on the left side. If the motorcycle is leaning to the right put the shims on the right side. The shims will go on the front and back of one side of the belly bracket.

Install the shims in-between belly bracket and motorcycle frame. The shims will go on top of front belly bracket tab and back bar of belly bracket.

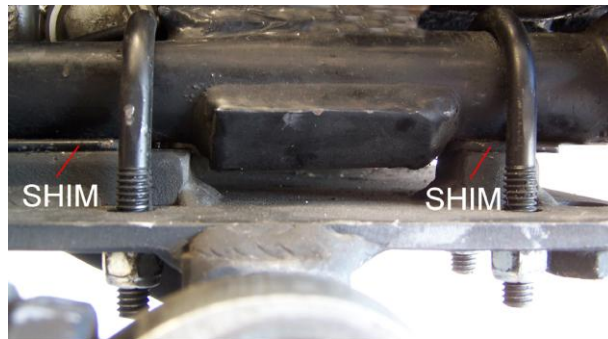

ILLUSTRATION OF SHIM PLACEMENT
BRACKET PICTURED MAY NOT MATCH YOUR BRACKET

SECTION 1

INSTALLATION OF H-D SPORTSTER 1000 (1972-1978)

MOUNTING HARDWARE

Place motorcycle on a clean flat surface. Be sure to tie down motorcycle so it does not tip over during installation of Voyager hardware. Installation is easier if motorcycle is in an upright position.

Disconnect negative cable from battery before beginning installation.

NOTE: The Voyager Convertible Kit was designed for a stock motorcycle from the manufacturer. Any after market products that are on a stock motorcycle may cause the installation process to not be done properly and may or may not need to be removed to be able to install the Voyager Convertible Kit completely. Be aware that your motorcycle and the same make & model as someone else's motorcycle may not have mufflers, body panels, frames, fenders and any other manufacturer parts that are attached to the motorcycle in the exact same place as yours. We at Motorcycle Tour Conversion, Inc. take that into consideration when we manufacture our parts to fit your motorcycle. Once in awhile you may need to modify your motorcycle slightly so that the Motorcycle Tour Conversion, Inc. hardware or suspension fits your motorcycle. Please call Motorcycle Tour Conversion, Inc. if you have any questions about installation with after market products or any modification of motorcycle and/or Motorcycle Tour Conversion, Inc. hardware.

A) 2 Rear Axle Brackets

- 1) Place motorcycle on a clean flat surface and support in an upright position. (tie-downs are helpful)
- 2) Support rear swing arm assembly and remove rear axle bolt. Replace rear axle bolt with the one provided with the Voyager kit. The hole for the cotter pin is not drilled in the bolt. Drill a hole after step 6.
- 3) Place right rear axle bracket on rear axle bolt and slide bolt back on.
- 4) Place the left rear axle bracket on axle bolt.
- 5) The swing arm attachment on our rear axle brackets should be touching the swing arm of the motorcycle. Clamp the swing arm attachment to the swing arm with the two hose clamps provided.
- 6) Replace axle nut.
- 7) After the new axle is reinstalled and adjusted, drill a hole in the bolt to accommodate the cotter pin.(it would be easier to remove axle, when drilling the cotter pin hole).

SECTION 1

INSTALLATION OF H-D SPORTSTER 1000 (1972-1978)

MOUNTING HARDWARE

B) Belly Bracket

- 1) Position the belly bracket so that the wide end is facing the front of frame.
- 2) Install (2) two U-bolts over frame (one on each side) and through the belly bracket. (wide end of belly bracket)
- 3) Install (4) four flat washers, and locking nuts.
- 4) Rear of belly bracket has bar with two u-bolts that attach to frame.
- 5) Install (4) four flat washers, and locking nuts.

NOTE: Due to a light front end on some H-D Sportsters you may experience more front end shake. Motorcycle Tour Conversion, Inc. recommends wider handle bars (buckhorn style) and a steering damper or stabilizer.



MOTORCYCLE TOUR CONVERSION, INC.
1530 TITANIUM DRIVE
OTTAWA, IL 61350

TOLL FREE: 877-434-7901
FAX: 815-434-8980

H-D SPORTSTER 1000 (1972-1978)

INSTALLATION MANUAL
US PATENT # 6,739,420

**WARRANTY WILL BE VOID IF INSTALLATION
IS NOT DONE PROPERLY**

**READ THIS MANUAL FULLY BEFORE
BEGINNING INSTALLATION**