

HARLEY-DAVIDSON DYNA 2006- REAR AXLE BRACKETS INSTALLED

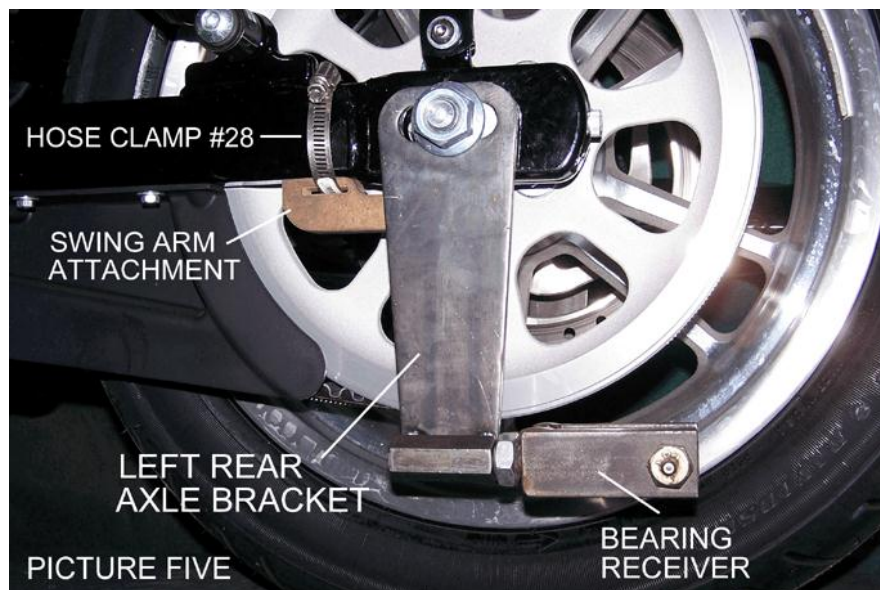

HARLEY-DAVIDSON DYNA 2006- BELLY BRACKET INSTALLED

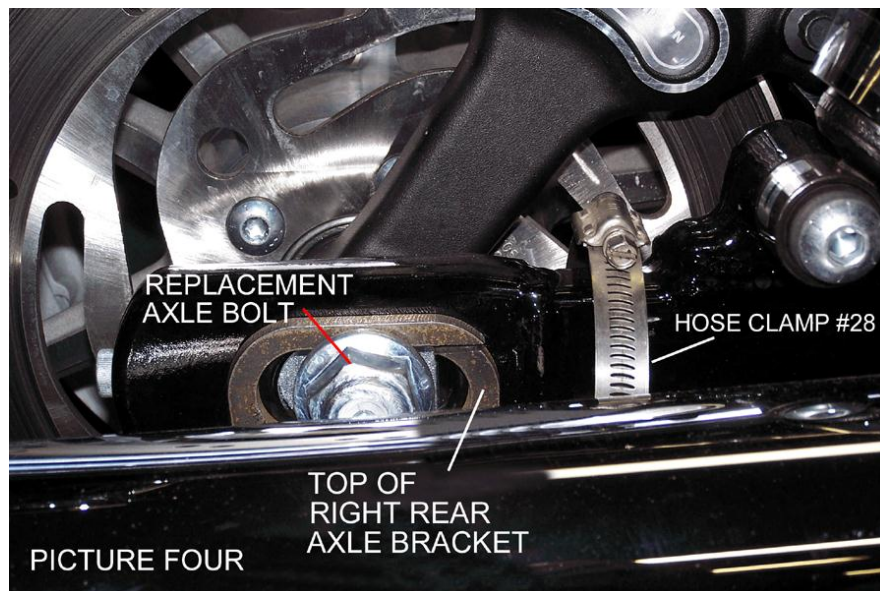
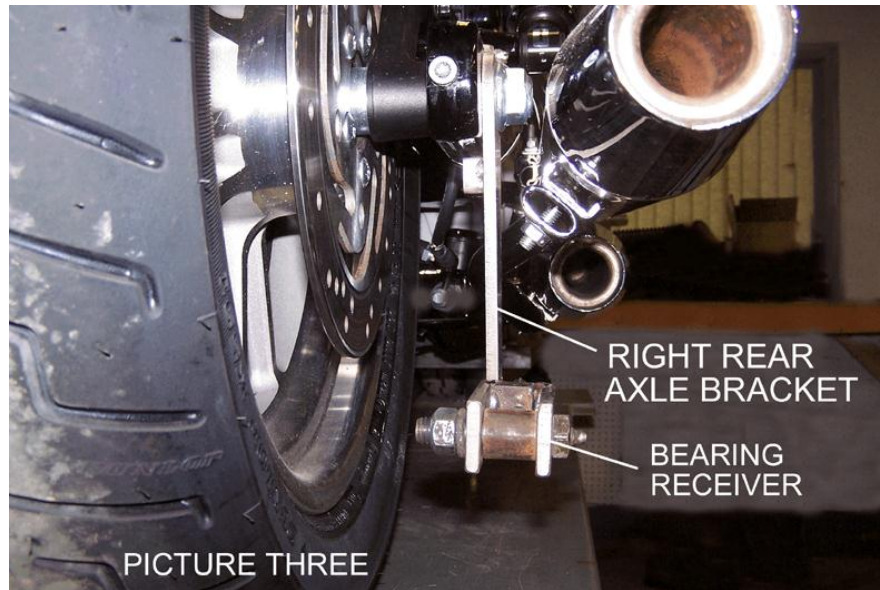
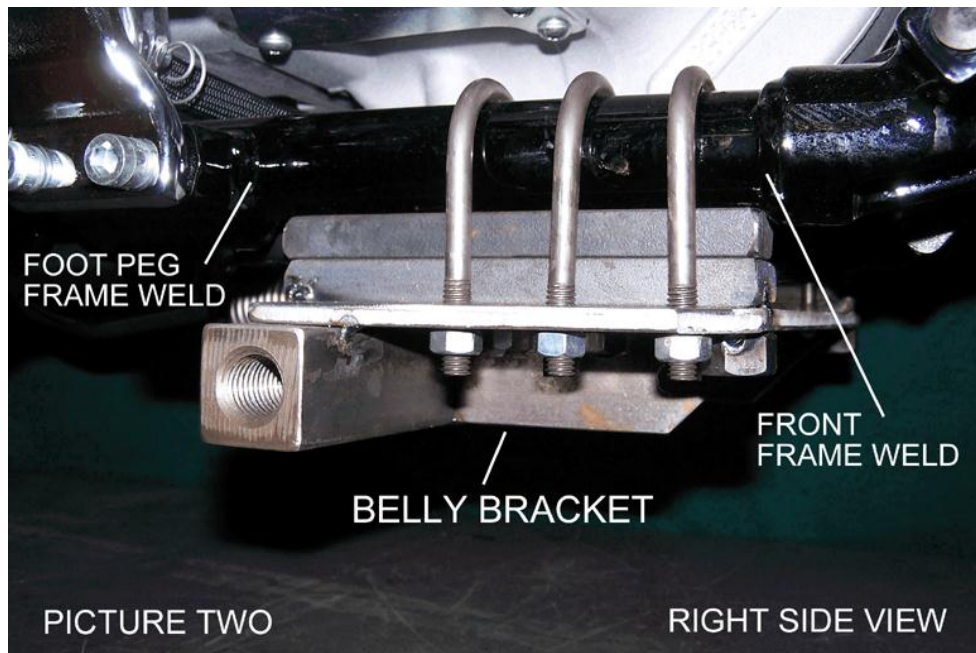
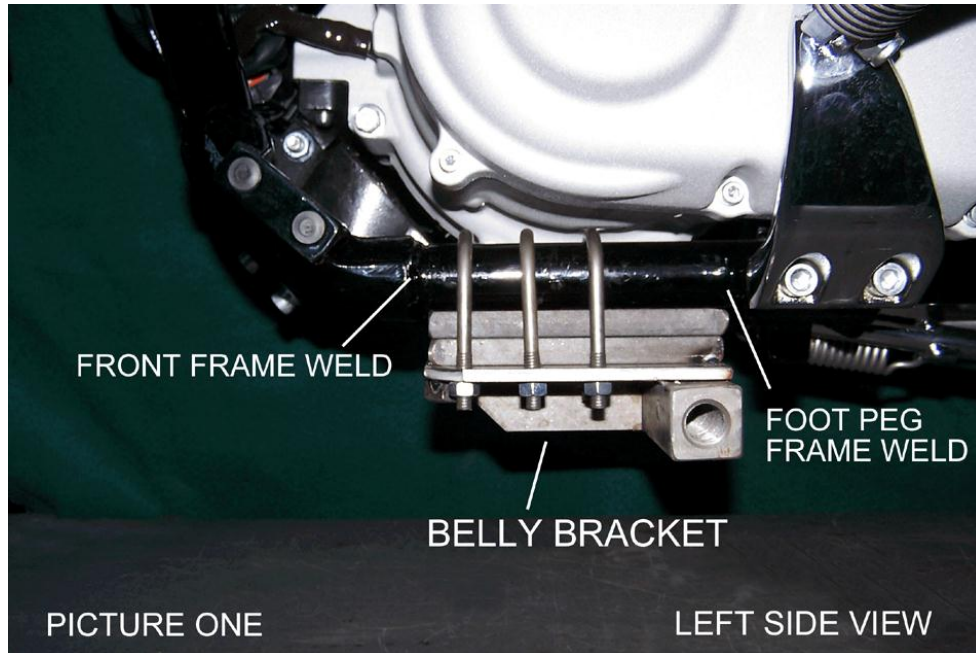

HARLEY-DAVIDSON DYNA 2006- DESCRIPTION OF PARTS

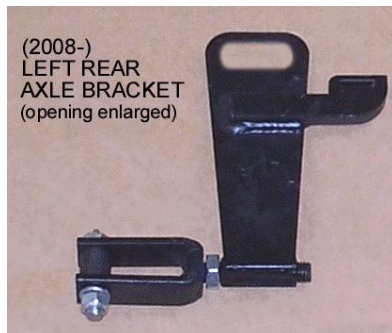
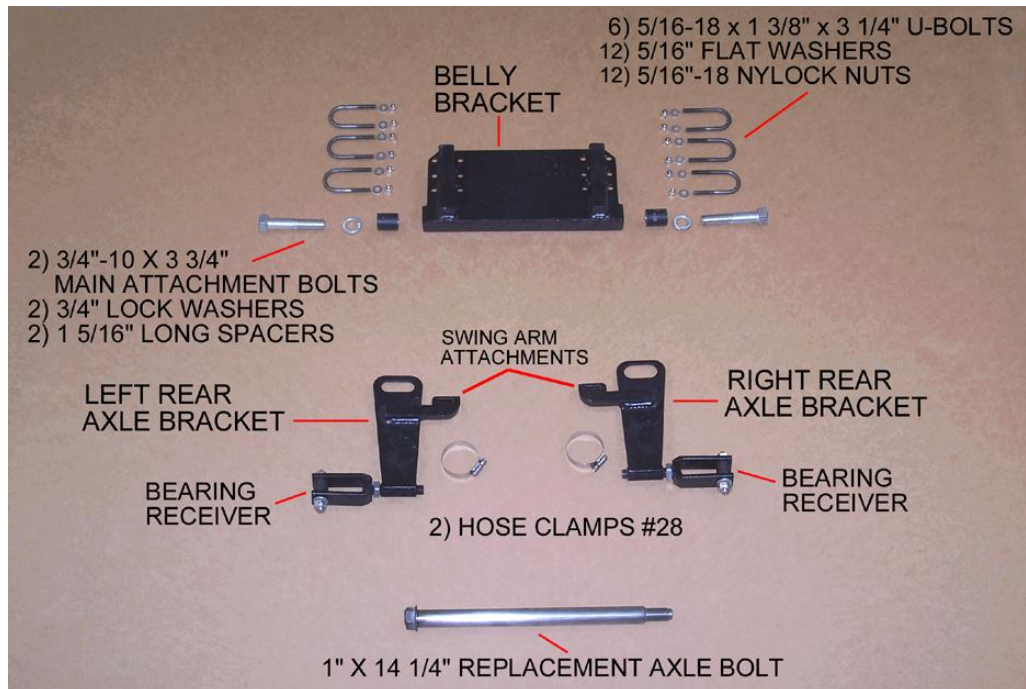

2008- H-D DYNA USES 14 1/4" x 24mm threads x 25mm diameter REPLACEMENT AXLE BOLT

One 6" shim – not shown in picture above.
You may or may not have to use the shim. See note below.

After installing the mounting hardware and attaching the Voyager frame to the belly bracket you may need a shim to make the motorcycle stand straight up and down.

The shim may be used on either the left or the right side depending on which way the motorcycle is leaning. If the motorcycle is leaning to the left put the shim on the left side. If the motorcycle is leaning to the right put the shim on the right side. The shim will go on the front and back of one side of the belly bracket.

Install the shim in-between belly bracket and motorcycle frame.

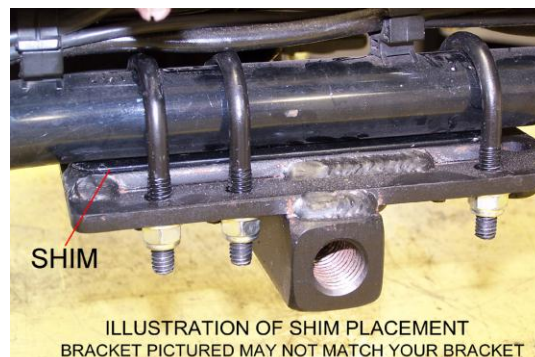

SECTION 1

INSTALLATION OF

HARLEY-DAVIDSON DYNA 2006- HARDWARE

Place motorcycle on a clean flat surface. Be sure to tie down motorcycle so it does not tip over during installation of Voyager hardware. Installation is easier if motorcycle is in an upright position.

Disconnect negative cable from battery before beginning installation.

NOTE: The Voyager Convertible Kit was designed for a stock motorcycle from the manufacturer. Any after market products that are on a stock motorcycle may cause the installation process to not be done properly and may or may not need to be removed to be able to install the Voyager Convertible Kit completely. Be aware that your motorcycle and the same make & model as someone else's motorcycle may not have mufflers, body panels, frames, fenders and any other manufacturer parts that are attached to the motorcycle in the exact same place as yours. We at Motorcycle Tour Conversion, Inc. take that into consideration when we manufacture our parts to fit your motorcycle. Once in awhile you may need to modify your motorcycle slightly so that the Motorcycle Tour Conversion, Inc. hardware or suspension fits your motorcycle. Please call Motorcycle Tour Conversion, Inc. if you have any questions about installation with after market products or any modification of motorcycle and/or Motorcycle Tour Conversion, Inc. hardware.

A) Belly Bracket

- 1) On left side of motorcycle install (3) 5/16"-18 x 1 3/8" x 3 1/4" U-bolts over motorcycle frame in-between the front frame weld and the foot peg frame weld.
- 2) On right side of motorcycle install (3) 5/16"-18 x 1 3/8" x 3 1/4" U-bolts over motorcycle frame in-between the front frame weld and the foot peg frame weld.
- 3) Install belly bracket to the U-bolts with (12) 5/16" flat washers and (12) 5/16"-18 nylock nuts

B) Rear Axle Brackets

Right Rear Axle Bracket

- 1) Remove motorcycle's rear muffler and then remove axle bolt.
- 2) Install right rear axle bracket over replacement axle bolt provided with kit, then install axle bolt back through motorcycle.

SECTION 1

INSTALLATION OF

HARLEY-DAVIDSON DYNA 2006- HARDWARE

Left Rear Axle Bracket

- 1) Install left rear axle bracket over axle bolt and replace factory washer and axle nut. (Do not tighten)
- 2) **NOTE:** Before you tighten axle nut completely, you must make sure swing arm attachments of axle brackets are touching swing arm of motorcycle.
- 3) Install #28 hose clamps through swing arm attachment of left and right rear axle brackets and around swing arm of motorcycle and tighten clamps.
- 4) Now tighten axle bolt.

NOTE: Due to a light front end on some H-D Dynas you may experience more front end shake. Motorcycle Tour Conversion, Inc. recommends wider handle bars (buckhorn style) and a steering damper or stabilizer.



MOTORCYCLE TOUR CONVERSION, INC.
1530 TITANIUM DRIVE
OTTAWA, IL 61350

TOLL FREE: 877-434-7901
FAX: 815-434-8980

HARLEY-DAVIDSON DYNA FAMILY 2006-

INSTALLATION MANUAL
US PATENT # 6,739,420

**WARRANTY WILL BE VOID IF INSTALLATION
IS NOT DONE PROPERLY**

**READ THIS MANUAL FULLY BEFORE
BEGINNING INSTALLATION OR DRIVING YOUR
MOTORCYCLE WITH THE VOYAGER KIT ATTACHED**